



HANDSWELL'S CHAIN INDUSTRIES

hands you well always

CHAINS FOR FERTILIZER INDUSTRY

The text 'KNOW US' is rendered in a large, bold, sans-serif font. The letters are white with a thin black outline, giving them a 3D or cutout appearance. The 'KNOW' is positioned above the 'US'. The background features a light gray gradient with abstract, wavy lines and a faint, stylized industrial facility or cityscape at the bottom.

HANDSWELL'S CHAIN INDUSTRIES LLP

Welcome to Handswell's Chain Industries LLP, where precision meets performance in the world of industrial conveyor chain manufacturing. With a rich legacy of excellence and a commitment to innovation, we have been a trusted partner for industries worldwide, providing top-tier conveyor chain solutions that drive efficiency and reliability.

At Handswell, we understand the critical role that conveyor chains play in the seamless operation of industrial processes. Our dedication to quality craftsmanship, cutting-edge technology, and customer satisfaction sets us apart in the industry



What sets us apart/ Why Us?

- 1. **Expertise and Experience:**** With over two decades of experience, our team of skilled professionals brings unparalleled expertise to every aspect of conveyor chain manufacturing. We have honed our craft, combining traditional craftsmanship with the latest advancements in materials and production techniques.
- 2. **Custom Solutions:**** We recognize that every industry has unique requirements. That's why we specialize in creating customized conveyor chain solutions tailored to meet the specific needs of our clients. From design to production, we work closely with our customers to ensure that our products exceed expectations.
- 3. **Innovation at the Core:**** In a rapidly evolving industrial landscape, we stay at the forefront of innovation. We are constantly innovating and investing in tools and technology such as **Laser, CNC** for **precise manufacturing** of parts. Our research and development team is dedicated to pushing the boundaries of what is possible, developing conveyor chain solutions that enhance performance, durability, and sustainability.



Our USP

4. **Quality Assurance:** Quality is non negotiable at **Handswell**. We adhere to rigorous quality control measures throughout the manufacturing process, ensuring that each conveyor chain leaving our facility meets the highest standards. Our commitment to quality extends beyond our products to encompass the entire customer experience.

5. **Manufacturing Facility:** Unlike other brands in the market, we have our own top class manufacturing plant with all the latest machines and infrastructure dedicated to conveyor chain manufacturing. We have been **white labelling** to **top brands** for more than **two decades** and our products have a wide reach not only in **India but also globally**.

6. **More Value compared to other brands:** Unlike the other known brands who are into buying and selling of products, **we are manufacturers with real facility and infrastructure**, who manufacture the products, buying directly from us **cuts the middleman fee**, hence better **value proposition**.



Customer Centric Approach

Our customers are at the heart of everything we do. We pride ourselves on **fostering long - term partnerships** by providing exceptional service, timely delivery, and ongoing support. Your success is our success, and we are dedicated to helping you achieve your operational goals.

Whether you are in **mining, manufacturing, agriculture, or any other industry** that relies on **conveyor systems**, Handswell's **Chain Industries** is your trusted partner for **premium conveyor chain** solutions. Explore the possibilities with us and experience the difference that quality and innovation can make in your operations.

BUCKET ELEVATOR CHAINS

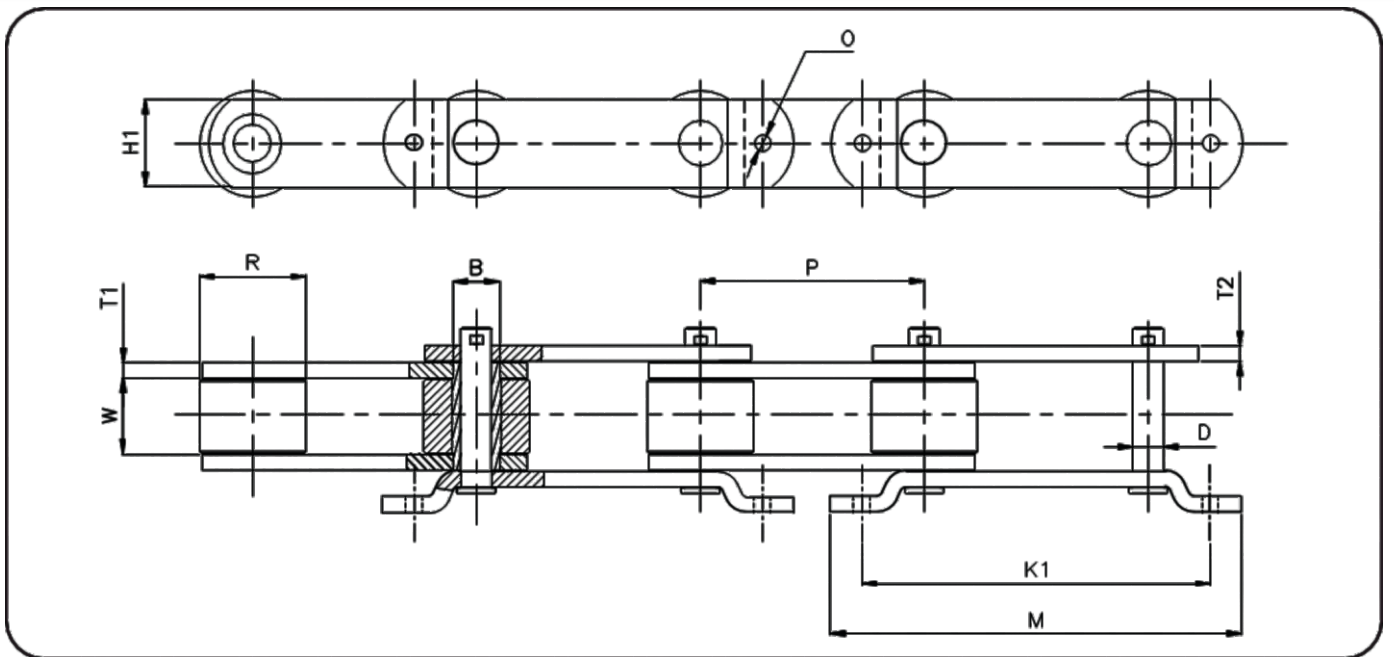

BUCKET ELEVATOR CHAINS

Chain no.	Pitch (P)	WIP (W)	Plate Ht. (H1)	I/P Thk. (T1)	O/P Thk. (T2)	Roller Dia. (R)	Pin Dia. (D)	Min. Breaking Load, Kgf	Att. Type	Att. Hole Pitch (K1)	Att. Hole Dia. (O)	Overall Width (M)
HLF12228A-BL	228.60	65.50	63.50	12.70	12.70	44.45	25.00	58000	G5	355.60	17.50	420.00
HLF16228H-BL	228.60	81.55	100.00	16.00	16.00	114.30	38.10	110000	G5	388.60	20.50	450.00
HLF12228L-BL	228.60	66.68	53.50	12.70	12.70	76.20	25.40	29500	G5	355.60	15.88	419.10
HLF16228-BL	228.60	77.70	88.90	16.00	16.00	108.00	31.75	90000	G5	355.60	16.80	420.00
HLF12228-BL	228.60	66.68	63.50	12.70	12.70	76.20	25.40	58000	G5	355.60	17.00	419.10

* All dimensions are nominal actual dimensions may vary (mm)

- Customizations such as special coatings, SS304 for better corrosion resistance can be done on all chains on request

BUCKET ELEVATOR CHAINS

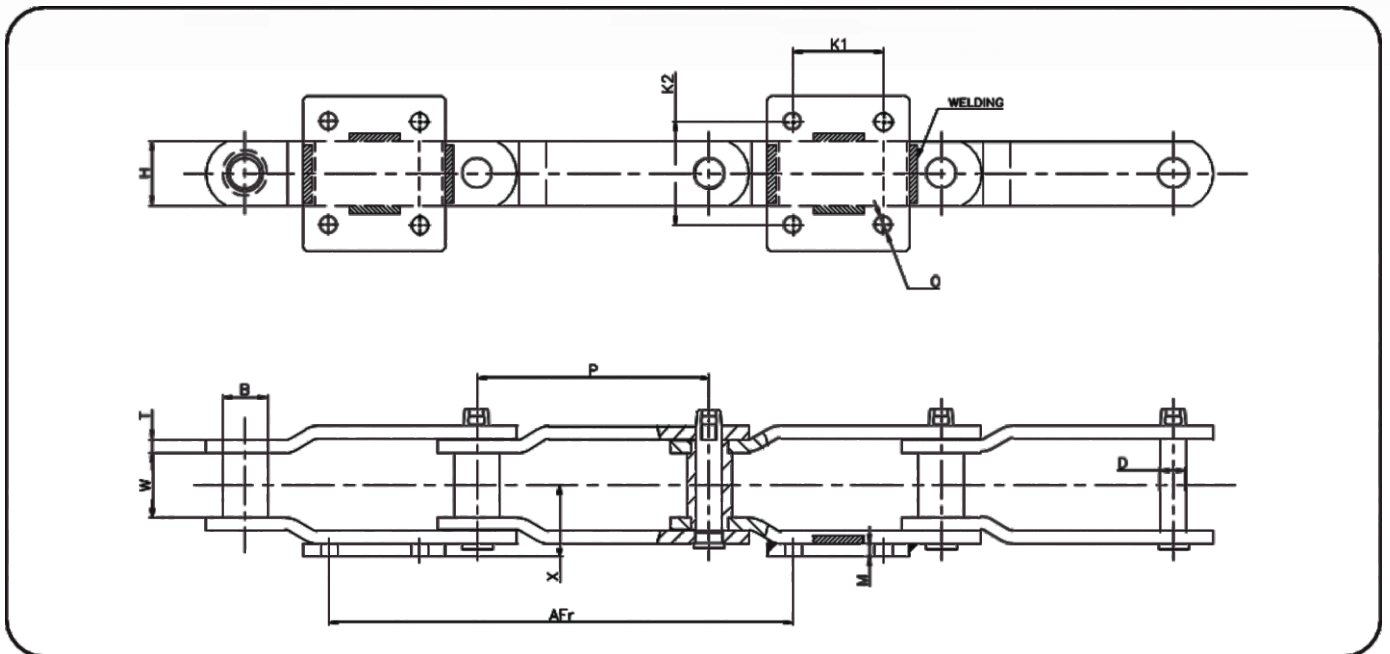

BUCKET ELEVATOR CHAINS

Chain no.	Pitch (P)	WIP (W)	Plate Ht. (H)	Plate Thk. (T1)	Att. Plate Thk. (M)	Bush Dia. (B)	Pin Dia. (D)	Min. Breaking Load, Kgs	Dist. b/w Attachments (Afr)	Att. Hole Pitch 1 (K1)	Att. Hole Pitch 2 (K2)	Att. Hole Dia. (O)	Att. Ht. from Chain Center (X)
HLF12228-OBL	228.60	63.50	63.50	12.70	12.70	44.45	25.40	58600	457.20	88.90	101.60	16.70	70.60
HLF16228-OBL	228.60	57.15	76.20	16.00	16.00	50.80	34.93	74500	457.20	88.90	101.60	16.70	78.20
HLF16228H-OBL	228.60	57.70	80.00	16.00	16.00	50.00	34.90	84250	457.20	88.90	115.00	17.00	79.00
HLF16228AL-OBL	228.60	76.20	90.00	16.00	16.00	60.35	38.10	100000	457.20	89.00	140.00	16.70	92.00
HLF16228A-OBL	228.60	76.20	90.00	16.00	16.00	60.35	38.10	117000	457.20	89.00	140.00	16.70	92.00
HLF16228AH-OBL	228.60	88.90	100.00	16.00	16.00	63.50	38.10	120000	457.20	89.00	152.40	17.50	98.00
HLF12228H-OBL	228.60	76.20	70.00	12.70	12.70	44.45	25.40	68000	457.20	88.90	120.65	16.70	78.00

*All dimensions are nominal actual dimensions may vary (mm)

• Customizations such as special coatings, SS304 for better corrosion resistance can be done on all chains on request

STANDARD ATTACHMENTS

1. A1, A2 Attachments

An A attachment has a bent link plate that extends out on one side of the chain, forming an L-shape. The attachment comes with one or two bolt holes and is designated as A1 or A2, respectively



Single strand with A2 attachment every link

2. K1, K2 Attachments

A K attachment has a bent link plate that extends out on both sides of the chain. The attachment comes with one or two bolt holes and is designated as K1 or K2, respectively



Single strand with K2 attachment every link

3. SA1, SA2 Attachments

With an SA attachment, the link plate is extended vertically on one side of the chain. The attachment comes with one or two bolt holes and is designated as SA1 or SA2, respectively



Single strand with SA2 attachment every link

4. SK1, SK2 Attachments

With an SK attachment, the link plate is extended vertically on both sides of the chain. The attachment comes with one or two bolt holes and is designated as SK1 or SK2, respectively (SK1 only for RS type).



Single strand with SK2 attachment every link

5. GNK1 Attachment

The GNK1 attachment indicates a chain with a bolt hole drilled into the center of the link plates on both sides of the chain.



Single strand with GNK1 attachment every link

6. EP Attachment (Extended Pin)

One end of the pins is extended on one side of the chain.



Single strand with EP attachment every link

7. Hollow Pin Chain

In Hollow Pin Chain, the pins have a hole, allowing for installation of various attachments.



Attachment Positioning

Chains can be assembled with an attachment on every link plate or at intervals of two or more links. However, placing an attachment on an outside link at an interval of an even number of links is convenient for maintenance purposes.

Single strand with A2 attachment every second link



Single strand with A1 attachment every fourth link



In-house production

**Unlike the other known brands
Handswell has its own real
manufacturing facility
dedicated for chain
manufacturing**



HANDSWELL'S CHAIN INDUSTRIES

hands you well always



M/S. HANDSWELL'S CHAIN INDUSTRIES LLP
G-2 BLOCK G2-1104
KG SIGNATURE CITY PH 2 ADAYALAMPATTU
TAMILNADU - 600 095

Website: www.handswellchains.com
Email: enquiry@handswellchains.com
Phone: +91-8248431963